













# Instruction Manual



## NeurOptics™ PLR-200™ Pupillometer

Symbol	Source/Compliance	Meaning
	Symbol #03-02 IEC 60878	<b>ATTENTION, consult ACCOMPANYING DOCUMENTS.</b>
	Symbol # 5333 IEC 60417 Symbol #02-03 IEC 60878	TYPE BF equipment
	Symbol # 02-02 IEC 60878	TYPE B equipment
	Symbol #5032 IEC 60417 Symbol #01-14 IEC 60878	This symbol indicates the equipment is suitable for alternating current.
	Symbol #5007 IEC 60417 Symbol #01-01 IEC 60878	Indicates ON (Power)
	Symbol #5008 IEC 60417 Symbol #01-02 IEC 60878	Indicates OFF (Power)
		Indicates Intermittent Use
		Indicates Non sterile
		Indicates Keep Dry
		Serial Number
		Model Number
		Lot Number

## Table of Contents

<i>Notices</i> .....	4
<i>Safety Information</i> .....	5
<i>Section 1 — Introduction</i> .....	8
<i>Features</i> .....	8
<i>Section 2 — Unpacking &amp; Setup</i>	
<i>Unpacking</i> .....	9
<i>Attaching the Eyecup</i> .....	10
<i>Connecting the Charging Station</i> .....	11
<i>Charging the Pupillometer</i> .....	12
<i>Section 3 — Using the Device</i>	
<i>Powering On and Menu Navigation</i> .....	14
<i>Taking a Measurement</i> .....	16
<i>Subject ID Number</i> .....	23
<i>Printing the Records</i> .....	24
<i>Browsing Records to View and Print</i> .....	26
<i>Menu Options</i> .....	27
<i>Section 4 — Cleaning and Maintenance</i>	
<i>Cleaning</i> .....	29
<i>Changing the Battery</i> .....	29
<i>Printer Maintenance</i> .....	30
<i>Section 5 — Downloading and Viewing Records on an External Computer</i> .....	31
<i>Appendices</i>	
<i>Appendix A—Troubleshooting</i> .....	33
<i>Appendix B—Contact &amp; Ordering Information</i> .....	35
<i>Appendix C—Phenomena Affecting Pupillary Measurement</i> .....	36
<i>Appendix D—Specifications</i> .....	37
<i>Warranty &amp; Returned Goods Policy</i> .....	39

## ***Copyright and Trademark Notice***

Copyright © 2010 NeurOptics, California.

This work is protected under Title 17 of the U.S. Code and is the sole property of NeurOptics, Inc. (the Company). No part of this document may be copied or otherwise reproduced, or stored in any electronic information retrieval system, except as specifically permitted under U.S. Copyright law, without the prior written consent of the Company.

NeurOptics™ and PLR-200™ are trademarks of NeurOptics, Inc.  
Seiko™ is a trademark of Seiko Instruments, Inc.

## ***EMC Notice***

NeurOptics™ PLR-200™ Pupillometer (device) generates, uses, and can radiate radio frequency energy. If not set up and used in accordance with the instructions in this manual, electromagnetic interference may result. The equipment has been tested and found to comply with the limits set forth in EN60601-1-2 for Medical Products. These limits provide reasonable protection against electromagnetic interference when operated in the intended use environments (e.g. hospitals, research laboratories) described in this manual.

## ***MRI Notice***

This device contains components whose operation can be affected by intense electromagnetic fields. Do not operate the device in a MRI environment or in the vicinity of high-frequency surgical diathermy equipment, defibrillators, or short-wave therapy equipment. Electromagnetic interference could disrupt the operation of the device.

## ***Intended Use Notice***

The NeurOptics Pupillometer is a handheld optical scanner which captures and analyzes a digital video of the human pupil responding to light stimulation. **It should only be operated by properly trained personnel.**

The results obtained from the pupillometer scans are used for information only and are not to be used for any diagnostic process.

## ***Regulatory Notice***

Federal law restricts the sale of this device except by or on order of a physician.

## ***Classification***

**Type of Equipment:** Medical Equipment, Class 1 886.1700

**Trade names:**

NeurOptics™ PLR-200™ Pupillometer

**Manufactured by:**

NeurOptics, Inc  
2082 Michelson Drive, Suite 450  
Irvine, CA 92612  
USA

If you have a question regarding this product, please contact NeurOptics at one of the numbers given in Appendix B.

## ***Indications for use***

Used for measuring a dilated or non-dilated pupil.

## ***Contraindications***

Avoid use when the orbit structure is damaged or surrounding soft tissue has an open lesion or edema.

## ***Safety Information***

### **Please review the following safety information prior to operating the device.**

Read the Operating Instructions fully before attempting to use the Pupillometer. Attempting to operate the device without fully understanding its features and functions may result in unsafe operating conditions and/or inaccurate results.

If you have a question regarding the installation, set up, operation, or maintenance of the device, contact NeurOptics as shown in Appendix B.

## Terms

<b>WARNINGS</b>	Identify conditions or practices that could result in serious adverse reactions or potential safety hazards.
<b>CAUTIONS</b>	Identify conditions or practices that could result in damage to the device or other equipment.
<b>NOTES</b>	Identify supplemental information to help you better understand how the device works.

## Warnings

**Warnings and Cautions appear throughout this manual where they are relevant. The Warnings and Cautions listed here apply generally any time you operate the device.**

**Use of the Pupillometer** - The Pupillometer is intended for use by trained clinical personnel, under the direction of a qualified physician.

If a problem is recognized while operating the device, the device must be removed from use and referred to qualified personnel for servicing. Using an inoperative device may result in inaccurate readings.

**Electric shock hazard** - Do not open the device or the docking station. There are no user serviceable parts. Refer *all* servicing to an authorized service technician. Opening up the device will void the warranty.

Use only the specified lithium ion rechargeable battery (P/N BATPUP-01) in the Pupillometer.

Use only power adapters which are shipped with the NeuroOptics Pupillometer system. Using unauthorized parts will void the warranty.

Use only the NeuroOptics charging station for charging Pupillometer batteries.

**Risk of fire or chemical burn** - The battery used in this device may present a risk of fire or chemical burn if mistreated. Do not disassemble, heat above 100 degrees C, incinerate, or dispose of in fire.

**Risk of fire or explosion** - Replace the Pupillometer battery with battery specified in Appendix B. Use of another battery may present a risk of fire or explosion. Dispose of battery promptly. Keep away from children.

## **Cautions**

**The following cautions apply any time you work with the device.**

A battery that is fully drained (i.e. void of any charge) may cause damage to the device and should be replaced.

Be careful when removing the eyecup to ensure that you do not damage the lens. Make sure that you do not “rotate” the lens when fitting or removing the eyecup.

**The following cautions apply when cleaning the device or when sterilizing device accessories.**

The internal components of the Pupillometer are not compatible with sterilization techniques, such as ETO, Steam Sterilization, Heat Sterilization and Gamma.

**DO NOT** submerge the device or pour cleaning liquids over or into the device.

**DO NOT** use acetone to clean any surface of the pupillometer or charger.

## Section 1 — Introduction

The NeurOptics PLR-200™ Pupillometer is a handheld optical scanner. It stimulates the eye with a flash of light and captures and analyzes a rapid sequence of digital images to obtain a temporal measurement of the diameter of a human pupil. The intensity and duration of the light stimulus can be set by the user. The system acquires images using a self-contained infrared illumination source and a digital camera. It analyzes the captured image data and displays a summary of the measurement in the LCD window. Data may also be printed out on an optional thermal printer or downloaded to an external computer via an infrared port (IrDA).

The NeurOptics PLR-200™ Pupillometer uses a menu driven graphical user interface (GUI), with a color LCD screen for data display. A keypad completes the user interface and enables manual entry of individual subject identification (ID) numbers and other information.

The Pupillometer is powered by a 4.2 volt rechargeable lithium ion battery.

Pupillary data sampled at 32fps and for a duration of 5 seconds is used in the calculation of a number of different pupillary variables that are displayed at the end of each single measurement.

The NeurOptics system includes a pupillometer, a rechargeable battery, two reusable eye cups, and a charging station. Options are listed in Appendix B and can be ordered separately.

### **Features**

- The NeurOptics PLR-200™ Pupillometer has been designed to be a lightweight device with a small footprint.
- The device has the capacity to store approximately 3000 measurements.
- The optional Seiko™ thermal printer enables hard copy printing of results.

## Section 2 — Unpacking and Setup

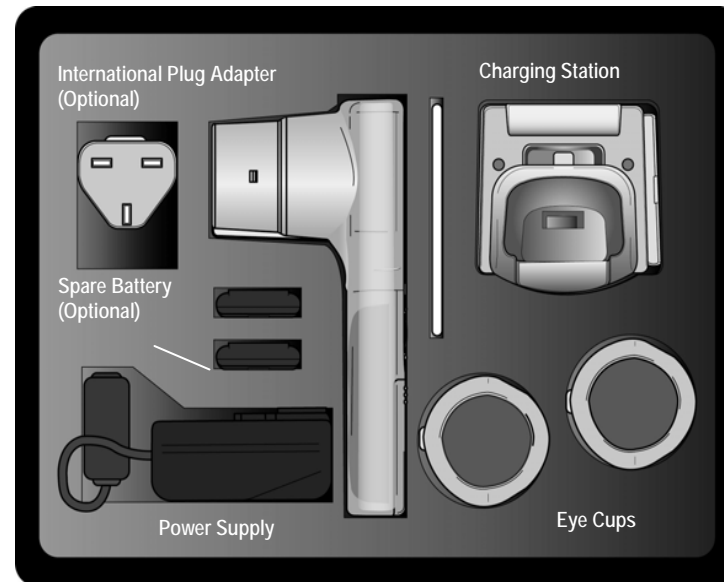

Figure 2.1

### *Unpacking*

The NeurOptics system is housed in a protective hard shell case. Included with your system are:

- The pupillometer
- Lithium ion battery
- Two eye cups
- Medical grade power supply for the charging station
- The charging station.

Please check the contents of your case (Figure 2.1) when delivered. If anything is damaged or missing please contact NeurOptics at once at 1-949-250-9792.

**DO NOT ATTEMPT TO USE A DAMAGED DEVICE!** The Pupillometer may not function correctly if it has been damaged or tampered with.

## Attaching the eye cup

The pupillometer should not be used without the eye cup positioned correctly.

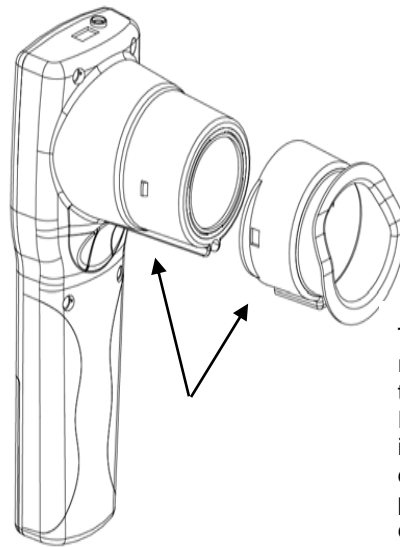

It is very important that the eye cup be correctly fitted. A snug fit helps reduce the possibility of stray light entering the eye while the scans are taking place.

The eye cup has a tab in the rim, which fits into the indentation in the lens shield of the Pupillometer. Position the tab in the eye cup rim into the indent in the lens shield and press into place. The tabs on either side of the lens shield should also snap into the holes on either side of the eye cup.

**Figure 2.2A**

The flexible, contoured eye cup fits onto the Pupillometer as shown in Figure 2.2A. The eye cup is reusable. To clean the eye cup, follow the instructions under Cleaning and Maintenance. To replace it or to order additional eye cups, call the number given in Appendix B, and request part number NEUR-2059-01.

---

**CAUTION**

Do not touch the lens when fitting or removing the cup. Damage to the lens may result.

---

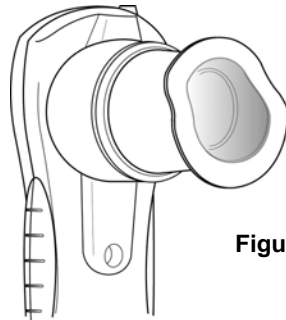

**Figure 2.2B**

When the eye cup is correctly positioned, the contour of the eye cup should be aligned horizontally as shown in figure 2.2B.

Always clean the eye cup before taking measurements on each subject (refer to Section 4).

## ***Connecting the Charging Station***

Connect the NeurOptics medical grade 4.2-volt power supply included with your system to the center plug in the charging station as shown in Figure 2.3. Connect the power supply to a suitable AC outlet. The other 2 plugs in the back of the charging station are for NeurOptics use only. After a second, you should see a blue LED illuminate on the plug of the power supply and a green LED on the front of the charging station.

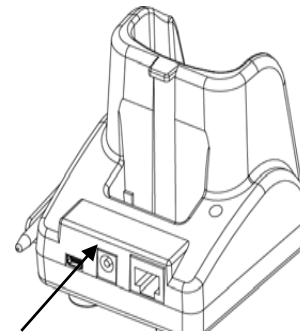

**Figure 2.3**

**Warning: ONLY use NeurOptics Part number NEUR-PWR1-01 power supply with the NeurOptics Charging Station. The device may be damaged if an incorrect power supply is used.**

## Charging the Pupillometer

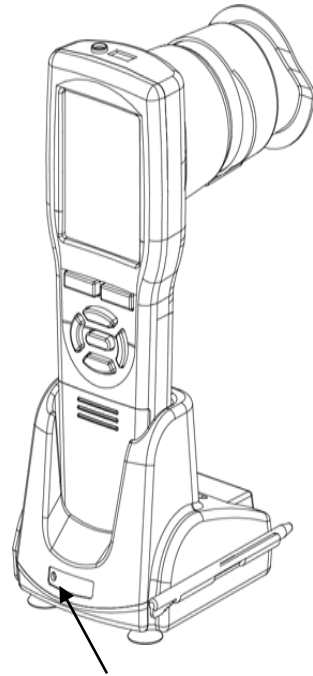

**Figure 2.4**

Install the Pupillometer battery into the Pupillometer (see Section 4). The battery must be fully charged prior to first use. This may take up to four hours. The battery status is indicated by the battery icon on the LCD screen of the device.

The arrow in Figure 2.4 points to the green LED on the front of the charging station which, when lit, indicates that the charging station is powered up correctly.

When placing the pupillometer into the charging station, the pupillometer should be inserted at a 90-degree angle straight down until a click is heard. The battery icon in the LCD screen will show a lightning bolt symbol indicating that the device is properly connected to the charging station.

When removing the pupillometer from the charging station, do not pull straight up. First, *rotate the device forward* and once it releases *then* pull it up. (See Figure 2.5).

When correctly installed, the eye cup on the Pupillometer should be facing the rear of the docking station with the keypad and screen towards the front as shown in Figure 2.4. This will orient the terminals on the Pupillometer with the terminals in the base of the docking station and enable a positive connection.

---

**CAUTION**

Do not try to pull the device up out of the charging station without first rotating it forward to release.

---

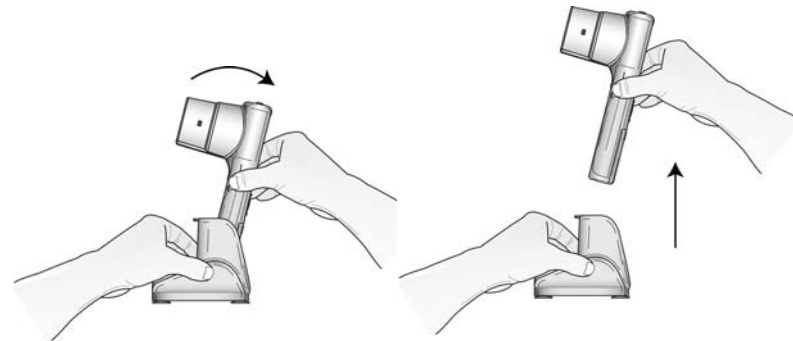

**Figure 2.5**

## Section 3 - Using the Device

### ***Powering On the Device and Menu Navigation***

Insert the battery and make sure it is fully charged before first usage (refer to Section 4). After the system has booted up, which takes a few seconds, the default measurement screen will display as shown in Figure 3.2A.

The main menu bar is displayed at the bottom of the default measurement screen and can be activated (Figure 3.2B) by pressing the down arrow ▼ of the directional keypad (Figure 3.1). Each icon in the Menu Bar corresponds to a different function of the Pupillometer. Notice that the key in the center of the keypad, labeled with a solid circle ●, is the SELECT key.

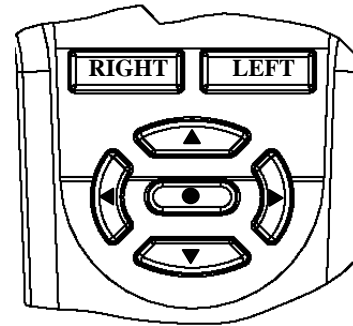
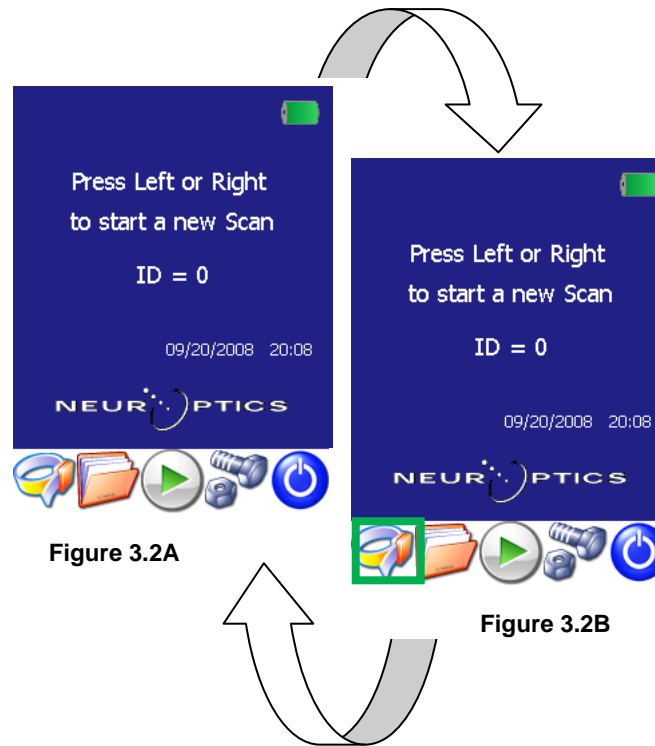

Figure 3.1

To activate the main menu bar, press the down arrow key ▼



To exit the Menu Bar or any submenu (see the next Section for an explanation and list of sub-menus) and return to the default measurement screen, press the LEFT or RIGHT key.

Once the Menu Bar has been activated by pressing the down arrow, the icon which is highlighted will have a square frame drawn around it. To highlight a different icon, use the left or right arrow keys on the keypad ◀ ▶. Once the desired icon has been highlighted, press the SELECT key on the keypad to select that icon.

---

## *Note*

***In order to conserve battery power while outside of the charging station, the Pupillometer will go into “sleep” mode after 3 minutes of inactivity. The device will turn itself off after 1 hour of inactivity.***

---

When in *sleep* mode outside of the charging station, the Pupillometer LCD backlight will be turned off and can be turned back on with a quick press-and-release of any button of the keypad. If the device is *turned off*, it can be turned back on by pressing and holding the up arrow key on the keypad for 3 seconds.

## ***Taking a Measurement***

### **Subject and Environment Preparation**

These are few general instructions:

- Instruct the subject to focus on a small target object (for example, a wall chart, or a dim flashing light) that is at least 10 or more feet (3 meters) away with the eye that is not being tested.
- Ask the subject to keep his head straight and both eyes wide open during both targeting and measurement. In some cases if targeting becomes a problem, it may be necessary to gently hold the subject's eye open with your finger.
- The operator should position the instrument at a right angle to the subject's axis of vision and any tilting of the instrument should be minimized (Figure 3.3A).
- It may be helpful for the operator to be at the same level as the subject when performing the scan to minimize tilting. If necessary, both subject and operator can sit down facing each other during targeting and measurement.

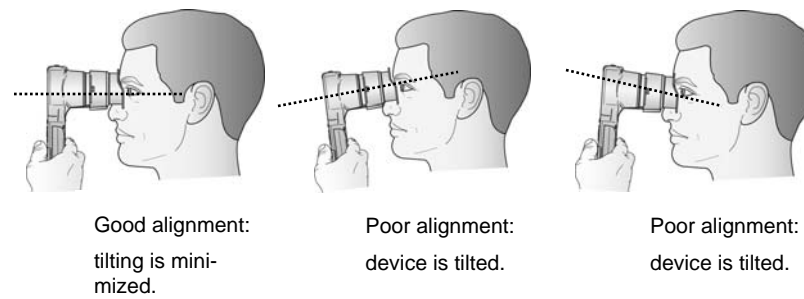

**Figure 3.3A**



**Figure 3.3B**

Pressing the RIGHT or LEFT button activates the Targeting phase. Press and hold down the RIGHT or LEFT button and keep the Pupillometer snugly up to the subject's eye. During this phase, a video image of the eye is displayed in the LCD window. The subject's pupil must be centered within the field of view (Figure 3.3B).

## Initiating the SCAN

A measurement can only be taken from the measurement screen (Figure 3.2A). To return to the main menu screen from any other window, menu, or submenu, press RIGHT or LEFT on the keypad. To initiate a new scan from the measurement screen, press RIGHT or LEFT on the keypad, depending on which eye is going to be measured.

---

### *Note*

*The RIGHT or LEFT keys will initiate a scan from the default measurement screen only (Figure 3.2A). If the RIGHT or LEFT key is pressed during any other system mode, the pupillometer will not initiate a new scan but instead will return to the default measurement screen (This is similar to the ESC [escape] key on a computer.)*

---

## Pupil Measurement

A pupil measurement is divided into three distinct phases (Figure 3.4).

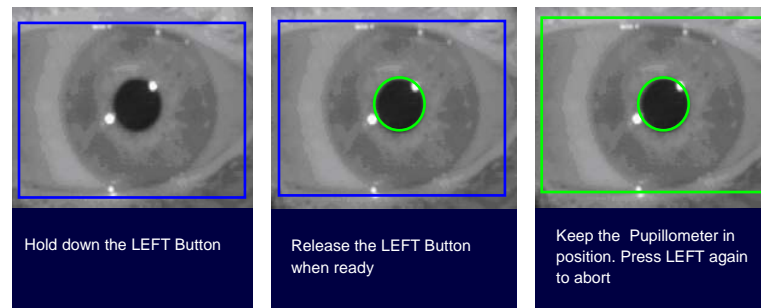

**Phase 1** - Either the RIGHT or the LEFT scan button is pressed. Video is enabled and displayed in the Pupillometer LCD screen. The user is required to hold the RIGHT or LEFT scan button down, position the Pupillometer on the subject's eye and center the subject's pupil in the center of the field of view indicated by the blue rectangular. This is called the Targeting phase.

**Phase 2** - The Pupillometer automatically detects the pupil. The pupil is marked with a green circle drawn around its perimeter. Release the button when ready to initiate the actual measurement (i.e., once the green circle appears around the pupil). This is called the Ready phase.

**Phase 3** - When the RIGHT or LEFT scan button is released, the actual pupil recording is initiated. Keep the Pupillometer firmly on the subject's eye for the entire duration of the recording which lasts 3 seconds. Do not move or remove the device during this period of time. If you need to abort the measurement, then press the RIGHT or LEFT button again. Once the measurement is complete, a message "Capture Done!" will be displayed at the bottom of the screen. At this point the device can be removed from the eye. This is called the Measurement phase.

Figure 3.4

If no pupil is found and detected in the field of view during the Targeting Phase, the Pupillometer will not transition to the next (Ready) Phase and the pupil scan cannot be initiated.

The Targeting and Measurement phases take a few seconds (depending on the duration of the Targeting phase), during which time the subject's eye should be wide open, with no blinking. While the measurement is being recorded, hold the Pupillometer as still as possible against the orbital rim, minimizing any tilting until the message "Capture Done!" is displayed on the screen (Refer to Figure 3.3A).

---

## WARNING

***If the green pupil boundary circle is NOT centered on the pupil perimeter during the Targeting phase, do not release the scan (RIGHT or LEFT) button.***

---

At the end of the Measurement phase the scan results will display almost immediately.

If the subject's eyelid is closed or droopy, instruct the subject to open his/her eyes as widely as possible or use your fingers to keep the eyelid open. If the subject is wearing heavy eye makeup which may interfere with the scan, hold the eyelid open as widely as possible.

The scan is complete when the message "Capture Done!" is displayed on the LCD screen. At that point the Pupillometer can be removed from the subject's eye.

When the analysis is complete, the results screen will display as shown in Figure 3.5.

---

## WARNING

***If critical parts of the measurement are affected by a tracking problem (e.g., blinks) then results are all displayed in red font. In this case, the measurement results are not valid and should not be relied upon and the measurement should be repeated. If the blink can be recovered by the analysis algorithm, then measurement results can still be evaluated and they are not displayed in red. In this case the blink will be reported in the graph with a darker line connecting the two extremities of the blink.***

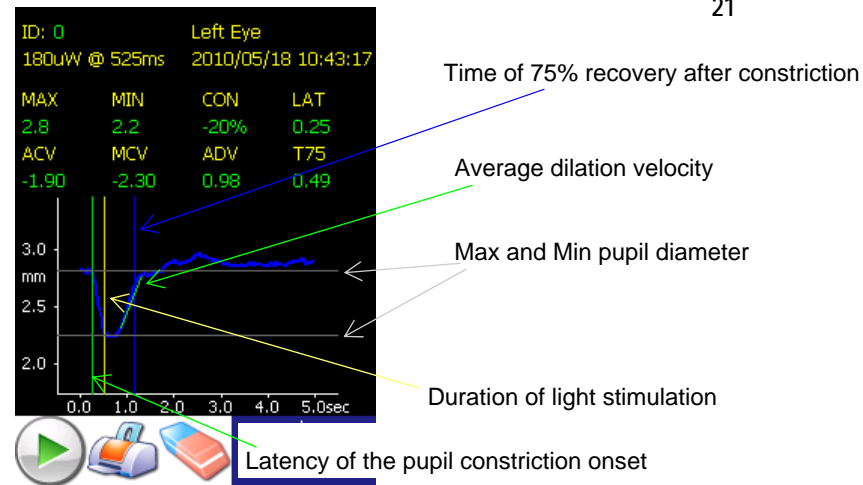

**Figure 3.5**

The results page shows a plot of the pupil response and reports the following information:

- **ID**, the identification code of the subject measured (for example 0 in Figure 3.5); which eye was measured (Left in the example), and the date and time of the measurement. Remember that if variables are displayed in red, then the measurement was affected by some problems, (e.g. an eye blink during the phase of pupil constriction). In this case, the measurement data should not be trusted and the measurement should be repeated.
- The **intensity** and **duration** of the light stimulation. In the example shown in Figure 3.5, the light stimulation intensity was 180 micro Watts for a total duration of 525 milliseconds. The duration of the light stimulation is also represented by a yellow vertical line superimposed over the pupil plot (0.0 sec is always the onset of the light stimulation).
- **MAX** and **MIN** represent the diameter of the pupil before the constriction (MAX=2.8 mm in this example) and just at the peak of the constriction (MIN=2.2 mm in this example), respectively. They are given in **millimeters** and are represented by two horizontal gray lines superimposed over the pupil plot (Figure 3.5). The variable **CON** is the percent of the constriction  $(MAX - MIN) / MAX$  as a percent.
- **LAT** is the **latency** and it represents the time of the onset of the constriction. It is given in **seconds** (for example 0.25 second in the example) and is represented by a vertical green line superimposed over the pupil plot.
- **ACV** and **MCV** are the **average** and the **maximum constriction velocity** and they are given in **millimeters/second**, respectively. The negative sign

is to differentiate the constriction from the opposite pupillary movement that is dilation. Both velocities refer to the constricting movement of the pupil diameter responding to the flash of light.

- **ADV** is the **dilation velocity** (given in **millimeters/second**) and represents the average pupillary velocity, when, after having reached the peak of the constriction, the pupil tends to recover and to dilate back to its initial resting size. Pupillary recovery after a light reflex constriction is usually characterized by an initial and more rapid phase followed by a much slower converging movement. The dilation velocity reported here refers to the initial and stronger recover and is indicated in the graph (see example in Figure 3.5) by a green line fit to the corresponding dilation phase of the pupil profile. If a blink occurred during the dilation, this variable might not be displayed.
- **T75** is the total time taken by the pupil to recover 75% of the initial resting pupil size after it reached the peak of constriction. It is given in **seconds** (0.49 in the example) and is represented by a vertical blue line superimposed on the pupil plot (Figure 3.5). If a blink occurred during the dilation, this variable might not be displayed.

---

## Note

*In case the intensity of the light stimulation is set at zero, there will be no pupil reflex. All of the dynamic variables described in Figure 3.5 are omitted. Instead, the mean and standard deviation of the pupil diameter evaluated over the entire duration of the experiment are provided in the results page.*

---

The short menu bar at the bottom of the results page can be activated with a press of the down arrow key ▼. Three options are available:



to PLAY the pupil video of the measurement.



to PRINT the current record (see section below).



to DELETE the current record.

## Subject Identification (ID) number <sup>23</sup>

To enable recall of subject data, a **Subject ID** number may be entered before initiating a scan. Assigning a Subject ID number is optional. If not entered, the new measurement will be associated to the latest and current ID which is always reminded in the default measurement screen (Figure 3.2A.). To assign a new ID number or to change it, select the ID bracelet icon on the main menu bar in the default measurement screen:



To enter a new ID, press SELECT on the first menu selection “New ID” (Figure 3.6) and the complete keyboard will be displayed in the screen (Figure 3.7). Any combination of lower and upper case letters and numbers can be used to create a new ID, up to a maximum of 9 digits or letters. Numbers or letters can be selected by navigating over the keyboard using the directional keypad and pressing SELECT (on the Pupillometer keypad) to select the current character or number or symbol. In order to shift between lower and upper case letters and numbers, select the “Shift” key (Figure 3.7). Press the “Enter” key on the displayed keyboard once the new ID is completed. The results of the subject’s next scans will be stored under this ID number.

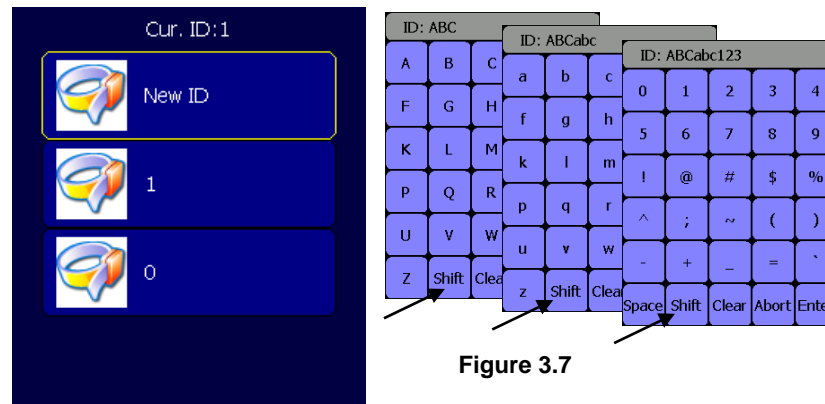
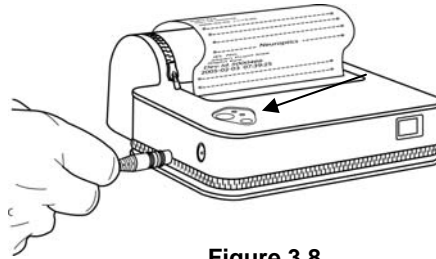

Figure 3.6

In case other ID numbers are present in the Pupillometer database stored in memory, these will be listed in the same window (for example in Figure 3.6 see ID 1 and ID 0). These IDs can be selected by using the directional keypad (arrow up and arrow down) and then pressing SELECT. This function is useful if you need to immediately re-enter a Subject ID already in the memory without the necessity of typing it again.

## Printing the Records

Attach the power supply to the printer as shown in Figure 3.8. Turn the printer on and the green light will illuminate.



**Figure 3.8**

The subject record currently displayed in the results window (Figure 3.5) can be printed by activating the short menu bar at the bottom of the results page (Figure 3.5) with a press of the down arrow key and then selecting the printer icon.

The range of the IrDA transceiver on the Pupillometer is less than one meter. If the Pupillometer is too far away from the printer, not pointed directly at the printer IR window (see Figure 3.9), or if the printer is not turned on, the error message **“Print Failed”** will be reported in the LCD of the Pupillometer. If the connection is successful and printing has been completed, a **“Print Done”** message will appear. It will take only few seconds for a single record to print.

During printing, hold the Pupillometer directly in front of the IR (infrared) window of the thermal printer as shown in Figure 3.9. A wireless connection is established with the printer through direct line of sight. The printout is a text summary of the results page. If you want to print a measurement other than the last measurement taken, refer to the “Browsing Records to View and Print” section.

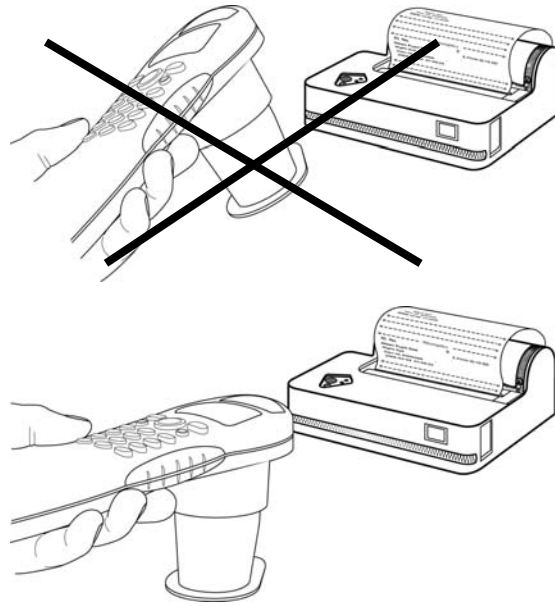

Figure 3.9

---

### *Note*

*The system will only print a record when data is displayed on the screen (i.e., after a measurement or when “browsing records”).*

*Consult the printer’s instruction manual for specific printer operation instructions.*

---

## Browsing records to view and print

Previous measurements can be browsed, retrieved and printed selecting the folder icon in the main menu from the default measurement screen:

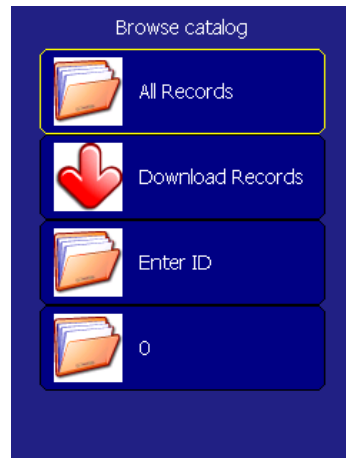

The red down arrow icon option in the browse records menu (Figure 3.10) serves to download all records saved in the Pupillometer's memory to an external computer (via infrared, IrDA). Please refer to the "Downloading and viewing records in an external computer" section.

**Figure 3.10**

In the Browse catalog window (Figure 3.10) you can select which subject to browse (and print). You can decide to browse all records in memory ("All Records", Figure 3.10) or a specific ID number ("Enter ID", Figure 3.10). For your convenience, the Browse catalog lists all the most recent ID numbers (For example, ID 0 in Figure 3.10) so that you can select directly from the catalog without having to re-enter the ID using the option "Enter ID".

All records corresponding to the ID specified in the Browse catalog window will be displayed (as in Figure 3.5). You can review each single record using the right and left arrow keys on the directional keypad (Figure 3.1). Each time a record is displayed in the LCD, you can decide to print it by selecting the printer icon on the menu bar located at the bottom of the record display.

## Menu Options

The main menu bar provides a few more functions:



### Settings

The settings window (Figure 3.11) is displayed when the nut and bolt icon is select in the main menu bar.

This window allows you to:



Dim the LCD backlight illumination. Press the SELECT key to toggle between different backlight illumination levels and then press RIGHT or LEFT to save and exit.



Change the Pupil-lometer date and time. If selected, the numeric keyboard will be displayed on the LCD (Figure 3.7). The current date and time will be reported on the top of the keyboard.

These setting can be changed by pressing "Clear" and re-entering the correct settings using the directional keypad of the Pupillometer (Figure 3.1). Select "Enter" on the LCD to save the new settings for the date and repeat the same steps for setting the time (whose keyboard is automatically displayed after date has been set). Note that time is in 24-hour format (i.e., from 00:00 to 23:59).

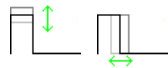

These two options allow you to change the intensity or strength of the light stimulation and the duration. Once an option has been selected, to change the corresponding value, press the left or right arrow keys on the keypad to toggle back and forth between different possible values (expressed in microwatts for the light pulse strength and in milliseconds for the light pulse duration). Maximum light strength is 180  $\mu$  W and maximum duration is 802 ms.

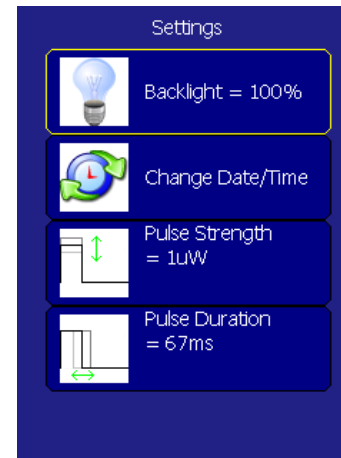

Figure 3.11



## **Play Video**

If this icon is selected from the main menu, a video of the latest valid scan will be played back on the pupillometer LCD.



## **Power Off**

This icon is for turning the device off. The Pupillometer will ask you for confirmation before performing this operation. The device can be powered back on by pressing the up arrow key for 3 continuous seconds.

## Section 4 - Cleaning & Maintenance

### ***Cleaning***

The NeurOptics Pupillometer and charging station are non sterile products.

**DO NOT** attempt to sterilize any part of the NeurOptics pupillometer system, as sterilization may damage the device.

To clean the surfaces of the NeurOptics Pupillometer, eye cup or charging station, use a soft, lint-free wipe with a quaternary disinfectant or isopropyl alcohol (IPA) 50% IPA/50% water.

**DO NOT** immerse or drip liquids on to the Pupillometer or charging station.

**DO NOT** use acetone to clean any surface of the Pupillometer or charger.

The LCD window should be cleaned using a soft, lint-free wipe and IPA.

Clean the lens with lens cleaning solution and a lint free cloth.

### ***Changing the Battery***

To maximize available battery reserve, it is recommended that the Pupillometer be stored in the connected charging station when not in use.

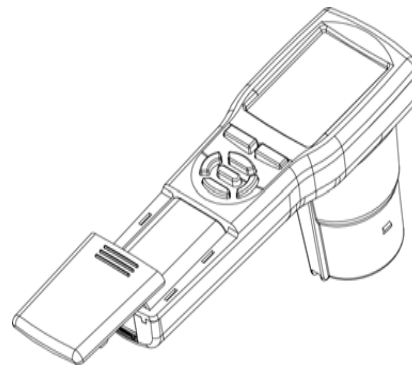

To change the battery, open the housing compartment by pressing down to release the catch and pulling outward. (Figure 4.1) Insert the battery with the terminals as indicated on the label in the battery compartment.

**Figure 4.1**

A battery status icon is visible on the main LCD screen which changes shape and color as the battery is depleted.

When the Pupillometer has a full charge, the battery status icon is shown as fully green:



As the charge decreases, the area inside the icon reduces and will eventually change into yellow:



A severely depleted battery is displayed by the level indicator being reduced to the very bottom and the color changes to red. A text message will appear which reads "Please charge device."



Place the Pupillometer into the Charging Station to charge the battery. During charging, a lightning bolt is overlaid on a blue battery icon; a completely charged battery is shown with a lightning bolt overlaid on a full green battery icon when the device is kept in the charger.

---

## *Note*

***Using the device when it is in red battery status is strongly discouraged.***

***Batteries should be recycled or disposed of in accordance with local ordinances in force in your area.***

---

## **Printer Maintenance**

The optional Seiko™ thermal printer is shipped with its own user's manual. Please refer to it for instructions as to loading paper, general use and safety.

## Section 5 — Downloading and viewing records on an external computer

All measurement data contained in the Pupillometer's memory can be downloaded to an external Windows based computer or laptop. The download is initiated by selecting the red down arrow "Download Records" icon in the Browse Records sub-menu (Figure 3.10). Highlight the "Download Records" key in the Browse Records sub-menu by using the up or down keys on the directional keypad and then press SELECT. The downloading process is similar to that for printing records (see Section "Printing the Records"). This time, the infrared window on top of the device should be pointed towards the infrared transceiver port in the external computer (or any IrDA infrared USB adapter that can be found on the market). While the "Download Records" key is highlighted, press and release the SELECT key. A text message reading "WinCE would like to send the following file to your computer via a wireless link: File: R\_20091019\_1227.dat (for example). Do you want to accept this file?"

Hint: Data are all encrypted and contained in a file named with the date and time of the moment of the download and extension "dat". For example, R\_20080909\_1030.dat is a file downloaded on September 9th, 2008 at 10:30.

After pressing "Yes", the next text message on the computer screen will read "Your computer is receiving a file or folder transfer." The pupillometer should be held in place until the downloading is complete. Upon completion, a text message will read "The files were received successfully from WinCE."

Once the file has been downloaded into the computer, locate the file and save it in a convenient location in the computer file system. To view all records in the file, insert the iDecoder disk provided by NeurOptics and execute the application iDecoder.exe (Figure 5.1). Use the "Load" button to open the file and browse through all records using the "Next" or "Prev" button. Finally, the entire file contents can be exported and saved as an ASCII file by pressing the "Save ASCII" button. The intent of the ASCII file is to allow the user to read the records outside the iDecoder viewer using Notepad or WordPad, or to write a personalized program to access this file and incorporate its contents into a preferred computational or statistical platform. A Matlab script can be provided for loading and processing the downloaded file in the Matlab workspace.



Figure 5.1

## Appendix A — Troubleshooting

<b>Issue</b>	<b>Possible Reason</b>	<b>Solution</b>
Device will not turn on	Using incorrect power supply	Use only power supply provided with pupillometer. Check label on power supply.
Device will not turn on	Power cord is not fully plugged into the wall or the charging station	Check connections
Device will not turn on	Battery not installed correctly in device	Remove and replace following instructions in Instructions for Use (IFU)
Device will not turn on	Battery completely discharged	Verify that battery is installed correctly into the device. Charge the battery by positioning the pupillometer into the charger (see instructions in IFU)
Battery will not charge	Device is not placed in charging station correctly	Make sure to push device straight down into the charging station following instructions in the IFU and that a lightning bolt symbol is displayed on the battery icon
Pupil measurement will not initiate after release of the RIGHT or LEFT key	Device not held correctly	Hold device at a 90-degree angle to subject's face. Make sure subject's eye is centered on the screen.
Pupil measurement will not initiate after release of the RIGHT or	Too much blinking or heavy makeup	Gently hold subject's eye open with your finger during measurement

<b><u>Issue</u></b>	<b><u>Possible Reason</u></b>	<b><u>Solution</u></b>
Record will not download	Pupillometer held too far away from the IrDA transceiver port or not in line of sight of IR window.	The IrDA port must be held in direct line of sight of infrared port in the pupillometer.
Record will not print	Pupillometer held too far away from printer or not in line of sight of IR window of printer	Printer must be held in direct line of sight of the infrared port in the pupillometer. See instructions in IFU
Record will not print	Measurement to print is not shown in the active screen	Browse to find record to print, then follow instructions in IFU.
Video will not play	Pupil video record not present in memory	Perform and complete a pupil measurement
Subject ID number is not displayed	“Enter” key on screen keyboard not pressed after entering Subject ID	Select and press “Enter” on screen keyboard after entering subjectID number.

## **Appendix B — Contact & Ordering Information**

The following **options and accessories** can be ordered from NeurOptics:

PLR-200™	NeurOptics Pupillometer – US
NEUR-PWR1-01	Pupillometer Charger/Power Supply – US
VIP-CHG-01	NeurOptics Pupillometer Charging Station
BATPUP-01	NeurOptics Pupillometer Rechargeable Battery
NEUR-2059-01	NeurOptics Pupillometer Eye Cup
NEUR-PRTE-30	Seiko™ Printer
49005-1	Seiko™ Printer Cover
49005-2	Seiko™ Printer Power Supply – US
49006	Seiko™ Printer Paper
NEUR-CASE-02	NeurOptics Pupillometer Carrying Case

For more information, please contact NeurOptics or visit  
[www.NeurOptics.com](http://www.NeurOptics.com)



**Distributed by:**

**NeurOptics, Inc.**

US Customer Service:

2082 Michelson Drive

Suite 450

Irvine, CA 92612

Tel: 949.250.9792 or 866.99PUPIL

Fax: 949.250.9796

info@NeurOptics.com

## **Appendix C**

### **Clinical Phenomena Affecting Pupillary Measurement**

#### **Vertex Variation:**

The distance of the corneal apex to the first optical surface of an instrument is referred to as the “vertex distance”. Natural biological variation in the general population results in an anatomical vertex distance range of approximately 12 mm.

For modern pupillometers which are used in close proximity to the eye, this 12 mm variation can account for a significant fraction of the object distance to the eye. Therefore, the projected scale of a pupillometer which has not been adjusted for vertex distance may result in a significant measurement error of pupil size. To compensate for potential differences in vertex distances, the NeurOptics Pupillometer utilizes the NeurOptics VIP™ (Vertex Invariant Pupillometry) technology, which reduces or eliminates the impact of vertex distance on pupillometry measurements.

## Appendix D — Specifications: NeurOptics Pupillometer - Model # PLR-200™

<b>Measurement Characteristic</b>	Input: Human pupil size varying from 1 mm-9 mm.  Output: Max and Min diameter, latency, average and maximum constriction velocity, average dilation velocity, time to 75% recovery  Accuracy: $\pm 0.1\text{mm}$ .
<b>Type of protection</b>	See Battery Charger (Class II )
<b>Degree of protection</b>	Pupillometer Eyecup – Type BF Applied Part provided
<b>Classification of the equipment against ingress of liquids</b>	Ordinary equipment
<b>Degree of safety of application in the presence of a flammable anesthetic mixture with air or with oxygen or nitrous oxide</b>	The equipment is not an AP or APG category equipment
<b>Mode of Operation</b>	On Demand battery operation
<b>Power Supply:</b>	4.2V 1800mA/hour Li: Ion Cell (battery)
<b>Operating Environment:</b>	Temperature Range: 18°C (65°F) to 30°C(86°F)  Relative Humidity: 20 % to 70 % RH. Non-condensing at all times
<b>Transportation and Storage Environment:</b>	Temperature: 0°C (32°F) to 75°C (167°F)  Relative Humidity: 10 % to 95 % RH Non-condensing at all times
<b>Dimensions:</b>	With Eyecup: 8.3" (211 mm) x 1.3" (33 mm) x 4.5" (114 mm)  Without Eyecup: 7.5" (191 mm) x 1.3" (33 mm) x 3.5" (89 mm)
<b>Weight:</b>	356 g $\pm$ 10g
<b>Classification:</b>	Class 1 LED product per IEC 60825

## Accessories

<b>NeuroOptics Charging Station - Model # VIP-CHG-01</b>	
<b>Degree of protection</b>	Type B Applied Equipment
<b>Type of protection against electric shock</b>	Class II Battery Charger
<b>Classification of the equipment against ingress of liquids</b>	Ordinary equipment
<b>Degree of safety of application in the presence of a flammable anesthetic mixture with air or with oxy-</b>	The equipment is not an AP or APG category equipment
<b>Mode of Operation</b>	Continuous operation
<b>Power Supply:</b>	Input: 100-240 VAC $\pm$ 8% Output: 6V, 2.8 Amps
<b>Power Line Frequency:</b>	50/60 Hz

<b>Seiko™ thermal printer Model # NEUR-PRTE-30</b>	Optional. See separate owners manual for instructions.
--	--

## Warranty

**A. Standard Limited Warranty.** NeurOptics (the Manufacturer) warrants to the original end user purchaser (the Purchaser) that the enclosed product (Product) purchased by the Purchaser, at the time of delivery to the Purchaser, shall be substantially free from defects in material and workmanship. The Manufacturer makes no warranty (express, implied, or statutory) for Products that are modified (except as expressly contemplated herein) or subjected to unusual physical stress, misuse, improper operation, neglect, improper testing, use in combination with other products or components other than those for which the Products were designed, or use in any manner or medical procedure for which the Products are not indicated. If the Product is opened up by anyone other than an authorized service technician of NeurOptics, the warranty shall be void.

**B. Remedy.** Purchaser's exclusive remedy and the Manufacturer's sole liability for breach of the foregoing warranty shall be, at the Manufacturer's sole option and election, to replace the Product or credit Purchaser for the net amount actually paid for any such Product; provided that (i) the Manufacturer is notified in writing within one (1) year after Purchaser's receipt of the Product that such Product failed to conform, including a detailed explanation in English of any alleged nonconformity; (ii) such Product is returned to the Manufacturer within one (1) year after Purchaser's receipt of the Product as designated by the Manufacturer and (iii) the Manufacturer is reasonably satisfied that the claimed nonconformities actually exist. Except as expressly provided in this paragraph, Purchaser shall not have the right to return Products to the Manufacturer without the Manufacturer's prior written consent.

**C. Exclusion of Other Warranties.** EXCEPT FOR THE LIMITED WARRANTY PROVIDED IN (A) ABOVE, NEUROPTICS GRANTS NO OTHER WARRANTIES OR CONDITIONS, EXPRESS OR IMPLIED, AND MANUFACTURER SPECIFICALLY DISCLAIMS THE IMPLIED WARRANTIES AND CONDITIONS OF MERCHANTABILITY AND FITNESS FOR A PARTICULAR PURPOSE. NEUROPTICS NEITHER ASSUMES NOR AUTHORIZES ANY OTHER PERSON TO ASSUME ANY OTHER LIABILITIES ARISING OUT OF OR IN CONNECTION WITH THE SALE OR USE OF ANY PRODUCT.

## Returned Goods Policy

Products must be returned in unopened packages, with manufacturer's seals intact, to be accepted for replacement or credit, unless returned due to a complaint of product defect or mislabeling. Determination of a product defect or mislabeling will be made by NeurOptics, which determination will be final. Products will not be accepted for replacement or credit if they have been in the possession of the customer for more than thirty (30) days.